

WORKING PRINCIPLES

It is used to separate unwanted low density materials in grain by aspiration.

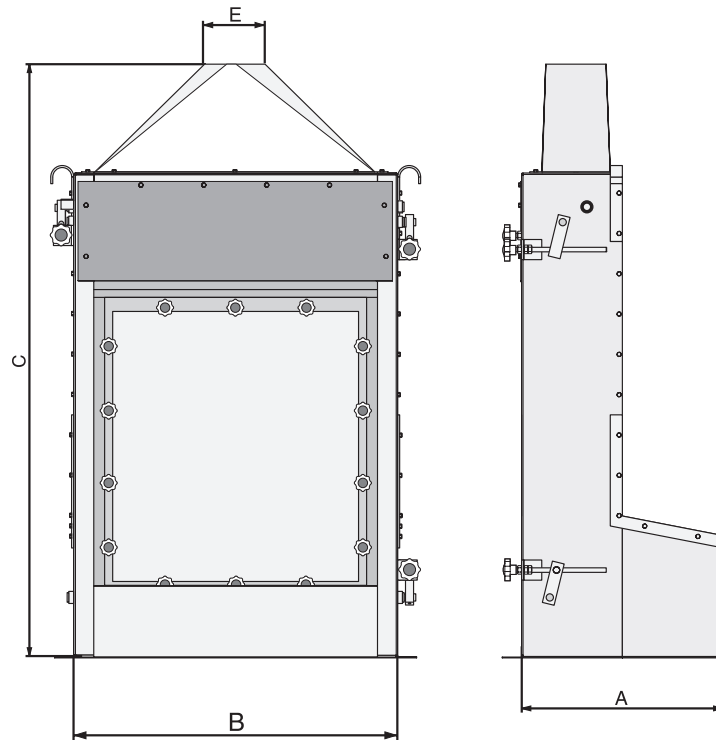

Product Data Sheet



Type	Technical Features				Dimensions(mm)						Weight (kg)
	Capacity (t/h)	Volume (m ³)	Power (kw)	Air Required (m ³ /min)	A	B	C	D	ØE	F	
GVH 060	4	0.3	--	40	500	600	1500	300	250	200	105
			0.085* (vibro)								140
GVH 080	6-8	0.43	--	50	500	800	1500	300	300	200	95
			0.085* (vibro)								125
GHV 100	10-14	0.65	--	80	500	1000	1500	300	350	200	120
			0.085* (vibro)								160
GHV 150	20	0.9	--	120	500	1500	1500	300	450	200	165
			0.17* (vibro)								295